



Introduction

Thank you for choosing one of our Zebra P4T Series Mobile Printers.

The P4T Series consists of two models. The **P4T** can print on direct thermal or thermal transfer media. The **RP4T** can print on direct or thermal transfer media and also encode special RFID media.

Because these printers are made by Zebra Technologies you can be assured of world-class support for all of your bar code printers, software, and supplies.

This document provides an easy reference for operating and maintaining either the P4T or the RP4T Mobile Printer.

Complete and current documentation for these printers is provided by the **P4T/RP4T User Guide** available on the Internet at: www.zebra.com/manuals.

! *Always refer to the Important Safety Information data sheet shipped with each printer and the Technical Bulletin shipped with each battery pack. These documents detail procedures to ensure maximum reliability and safety while using this printer.*

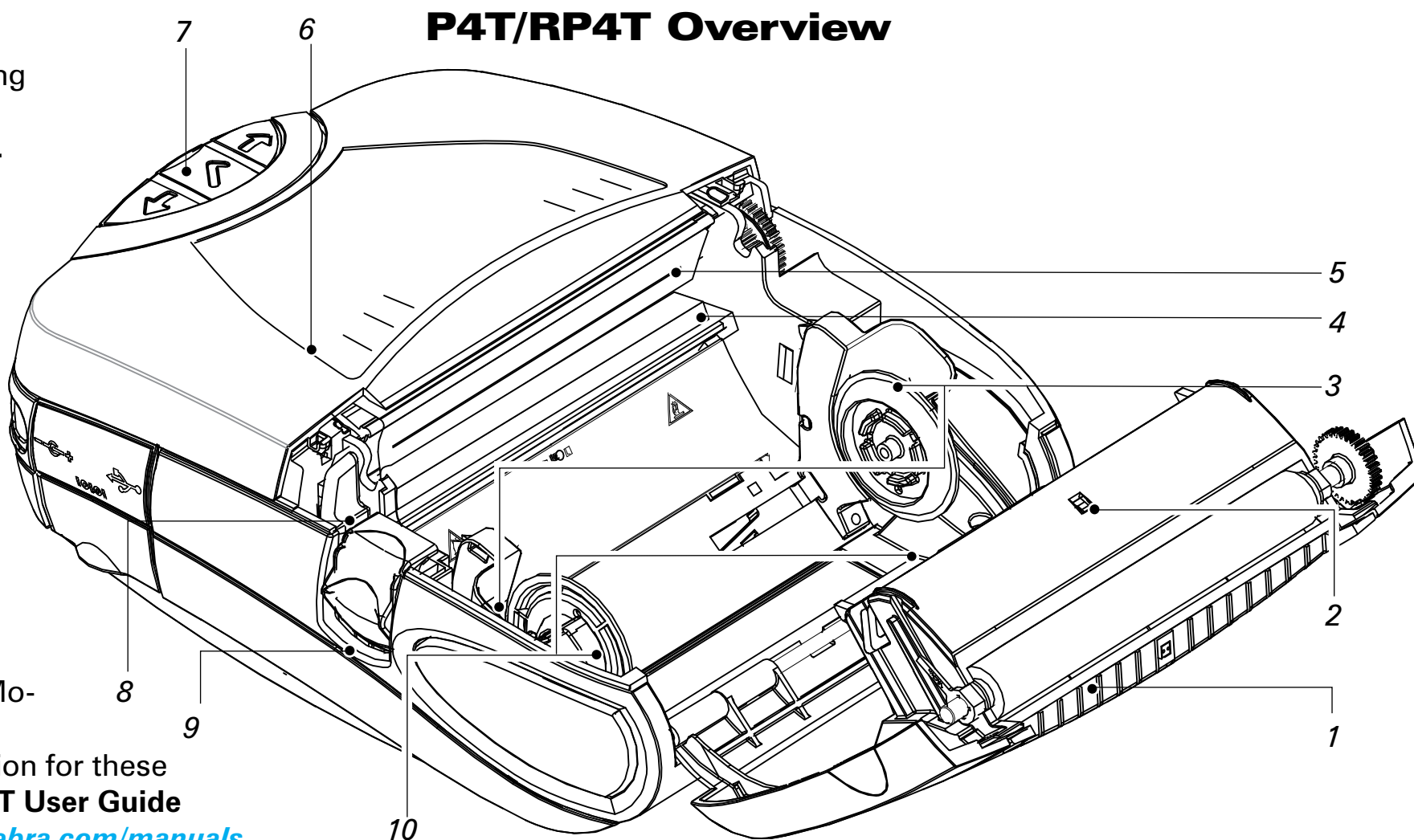

1. Platen Roller
2. Bar Sensor
3. Media Support
4. RFID Reader/Encoder (RP4T only)
5. Printhead
6. Ribbon Cartridge Cover
7. Control Panel
8. Ribbon Cartridge Cover Latch
9. Media Cover Latch
10. Media Support Disks
11. Label Peeler
12. Media Cover
13. External Media Access (optional)
14. Battery
15. Battery Charging Receptacle
16. RS232 Communications Port
17. USB Port

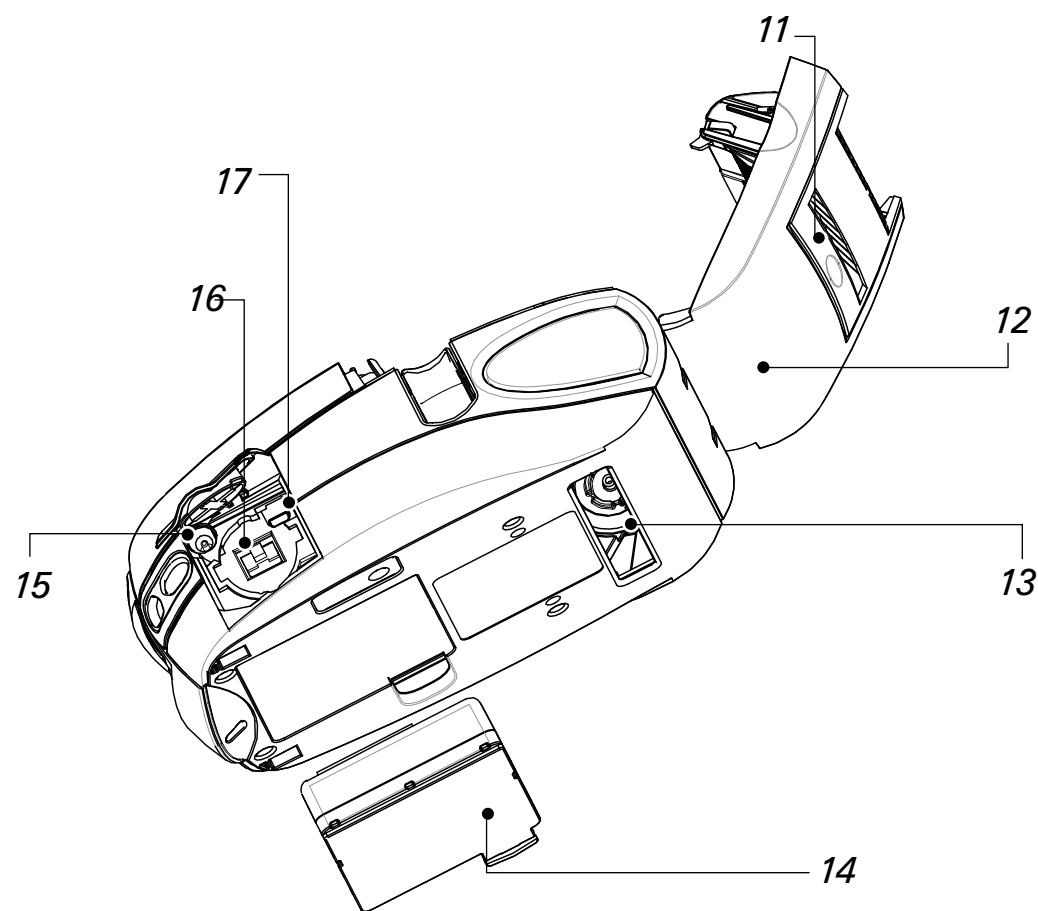

Charge the Battery Pack

 **Battery packs are shipped uncharged. Remove protective shrink-wrap and labels from new battery packs and allow them to charge completely prior to initial use.**

 **The printer cannot be used while charging with the single charger.**

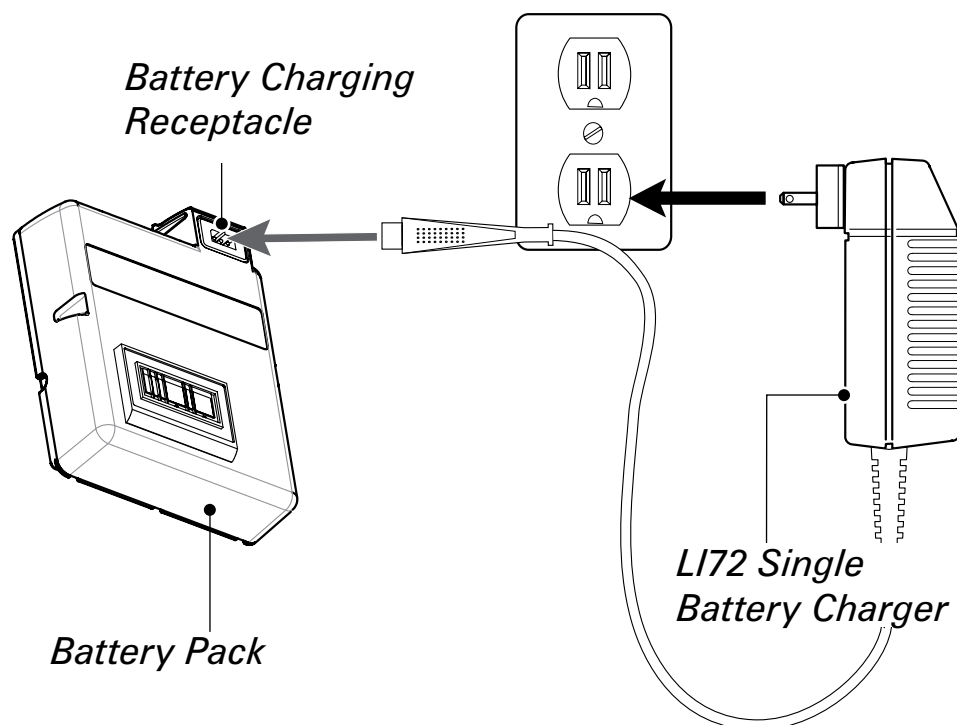

Using the Single Battery Charger

If the Battery Pack is new, remove its protective wrapping and discard the warning label covering the battery contacts. If you are charging a previously used Battery Pack, remove it from the printer.

Insert the plug from the Charger cable into the Battery Charging Receptacle. Plug the Charger into an appropriate AC outlet.

The light on the front of the charger will indicate the battery pack's charge status.

 **The printer may be used while charging the battery pack with the AC adapter. However, prolonged use of the printer while charging will greatly increase charge times.**

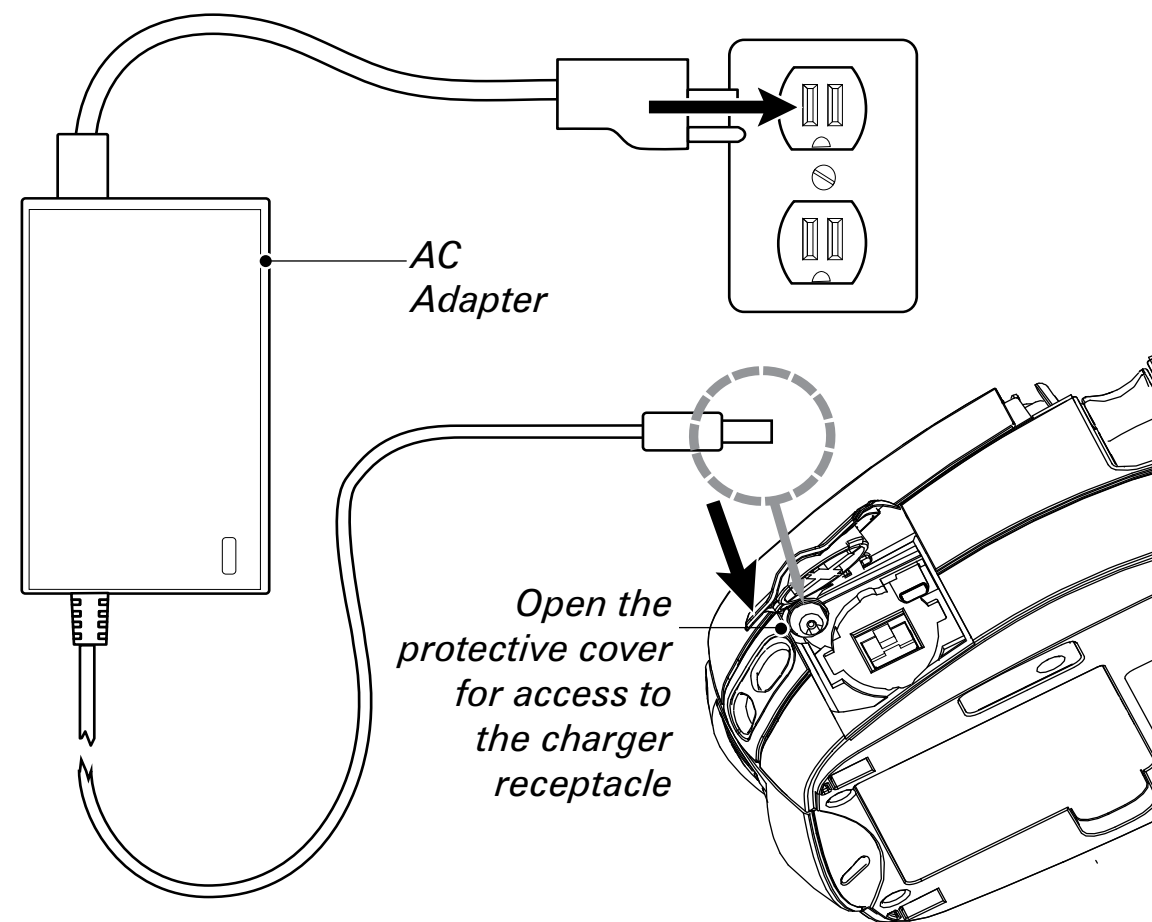

Using the AC Adapter

If the Battery Pack is new, remove its protective wrapping and discard the warning label covering the battery contacts. Install the Battery Pack in the printer.

Insert the plug from the AC Adapter cable into the Battery Charging Receptacle. Plug the Adapter into an AC outlet.

 **Consult the P4T/RP4T User's Guide available at www.zebra.com/manuals for complete information on charging batteries on P4T Series printers.**

UCLI72-4 Quad Charger

The UCLI72-4 Quad Charger is an optional accessory kit allowing simultaneous charging of up to four battery packs.

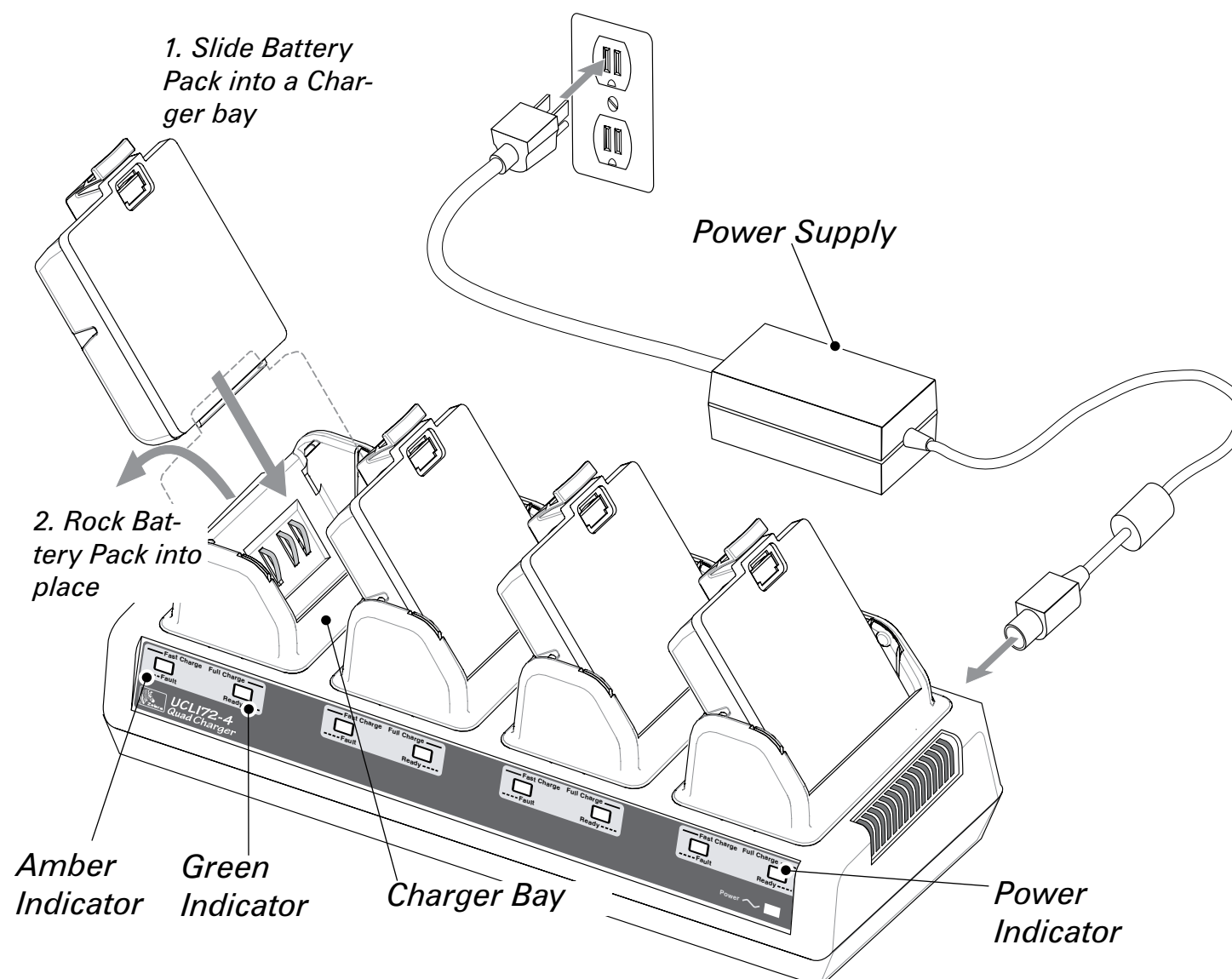

The UCLI72-4 Quad Charger is designed to charge up to four battery packs simultaneously. Charging time is as follows:

Battery Status	Charging Time
80% charged	2.5 Hrs.
Full charge	5 Hrs.

Plug a battery pack into any one of the four charging bays as shown opposite, noting the orientation of the battery pack. Slide the battery pack into the charging bay until it stops. Then rock the battery pack back until it snaps into place. The amber indicator directly under the battery pack being charged will turn on if the battery pack is properly inserted.

The indicators under each battery pack will allow you to monitor the charging process per the table below:

Amber	Green	Battery Status
On	Off	Charging
On	Flashing	80% charged (O.K. to use)
Off	On	Completely Charged
Flashing	Off	Faulty battery pack



For more information refer to the instructions included with the UCLI72-4 Quad Charger, or to the more detailed discussion of the quad charger in the P4T/RP4T User Guide.

The UCLI72-4 Quad Charger has a safety feature which stops charging after six hours regardless of the battery pack's charge state.

Install the Battery Pack

! Always use Zebra approved battery packs and media for maximum performance and superior printing results. P4T Series printers will not operate with non-Zebra batteries.

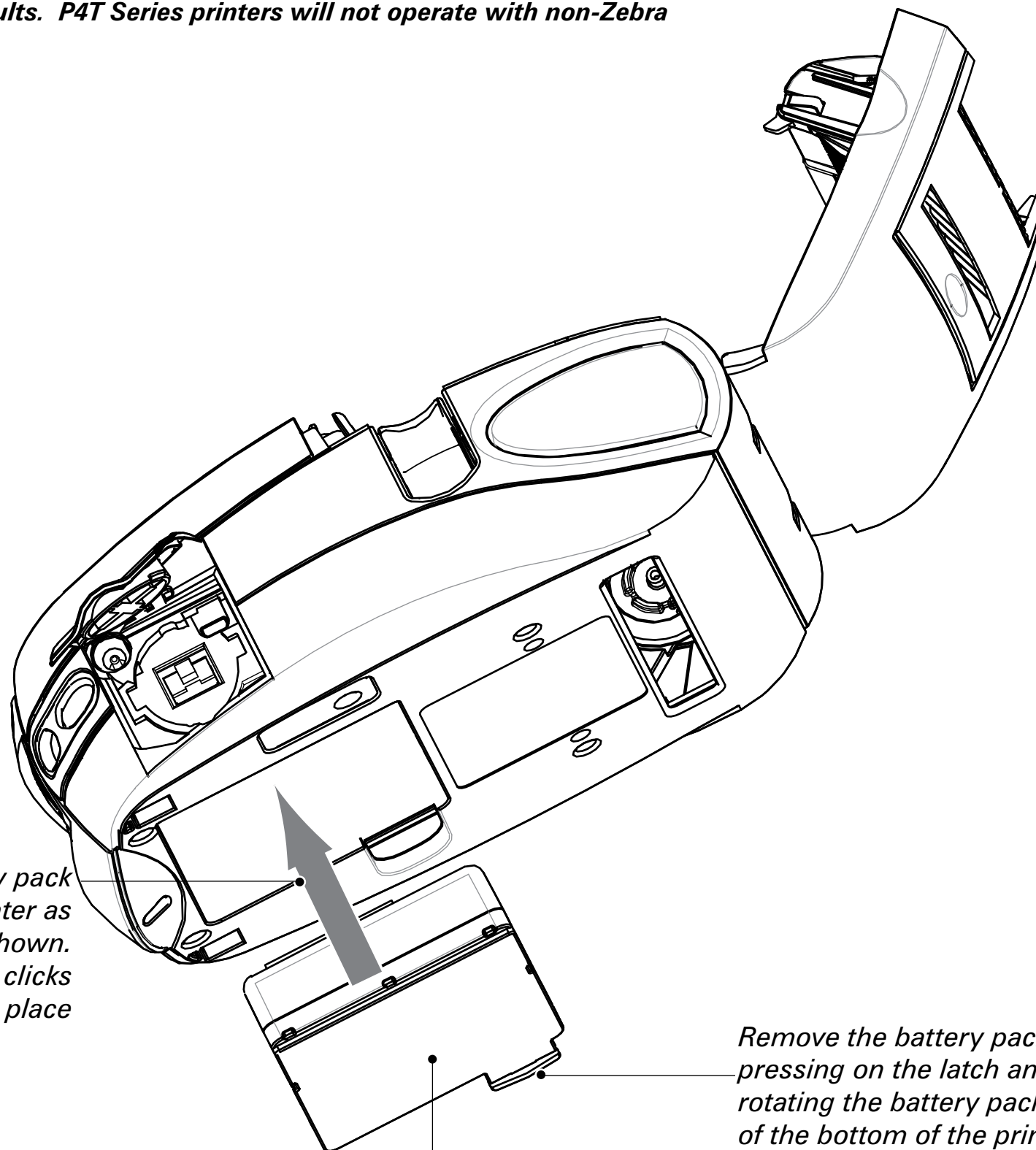

Insert a fully charged battery pack into the bottom of the printer as shown. Press battery pack until it clicks into place

Remove the battery pack by pressing on the latch and rotating the battery pack out of the bottom of the printer.

Battery Pack

Load the Media

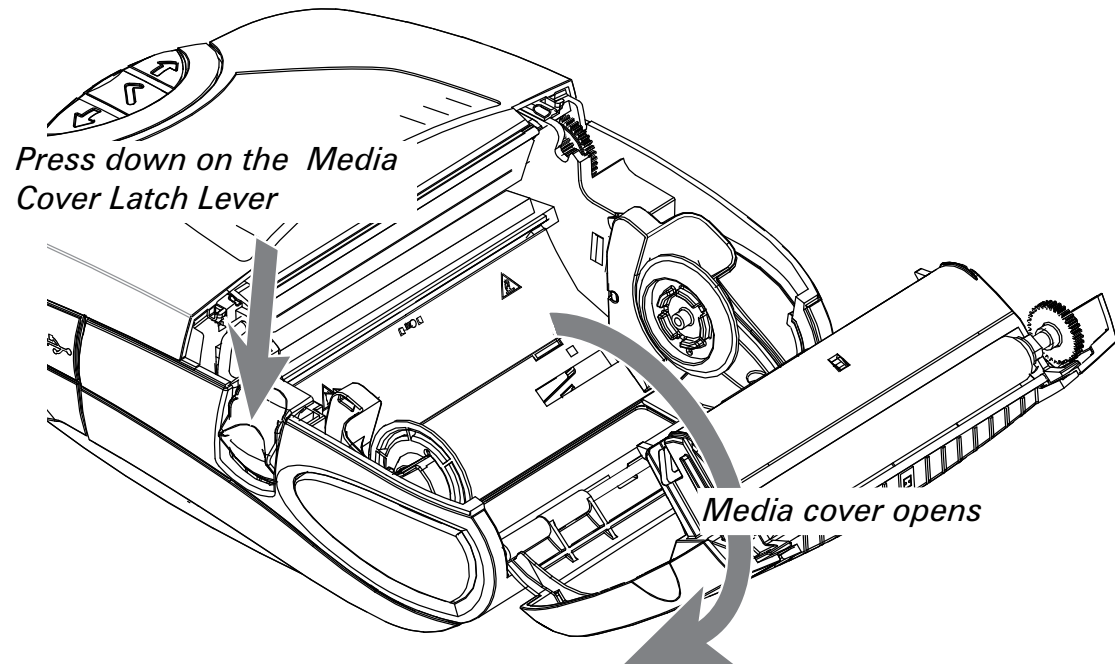

1. Open the Media Cover

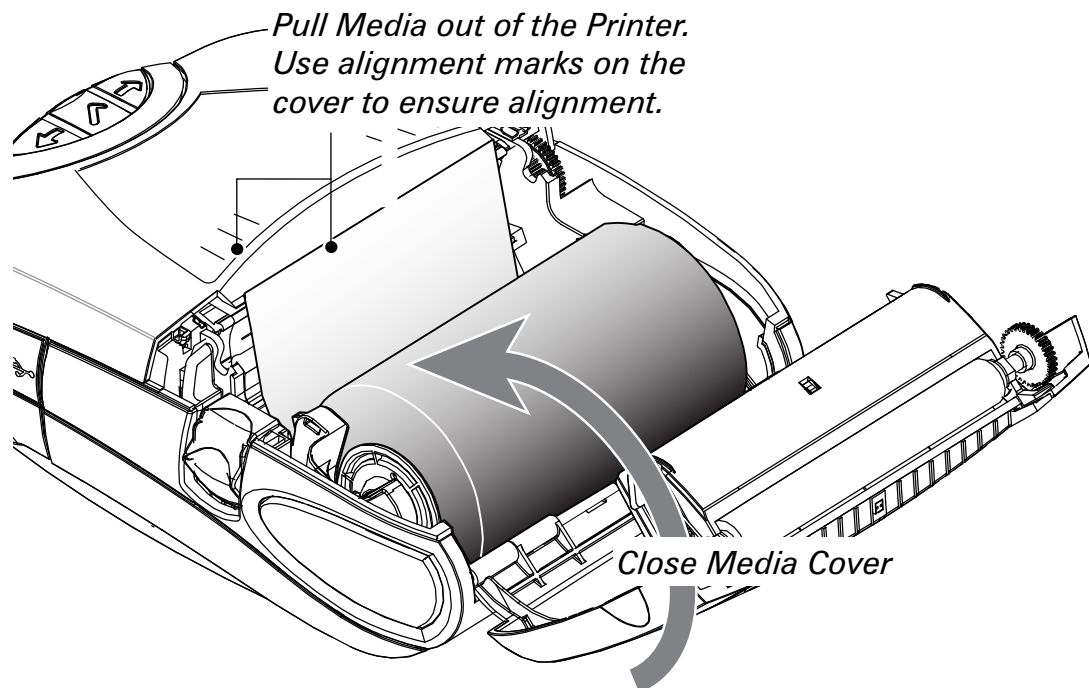

3. Close the Media Cover

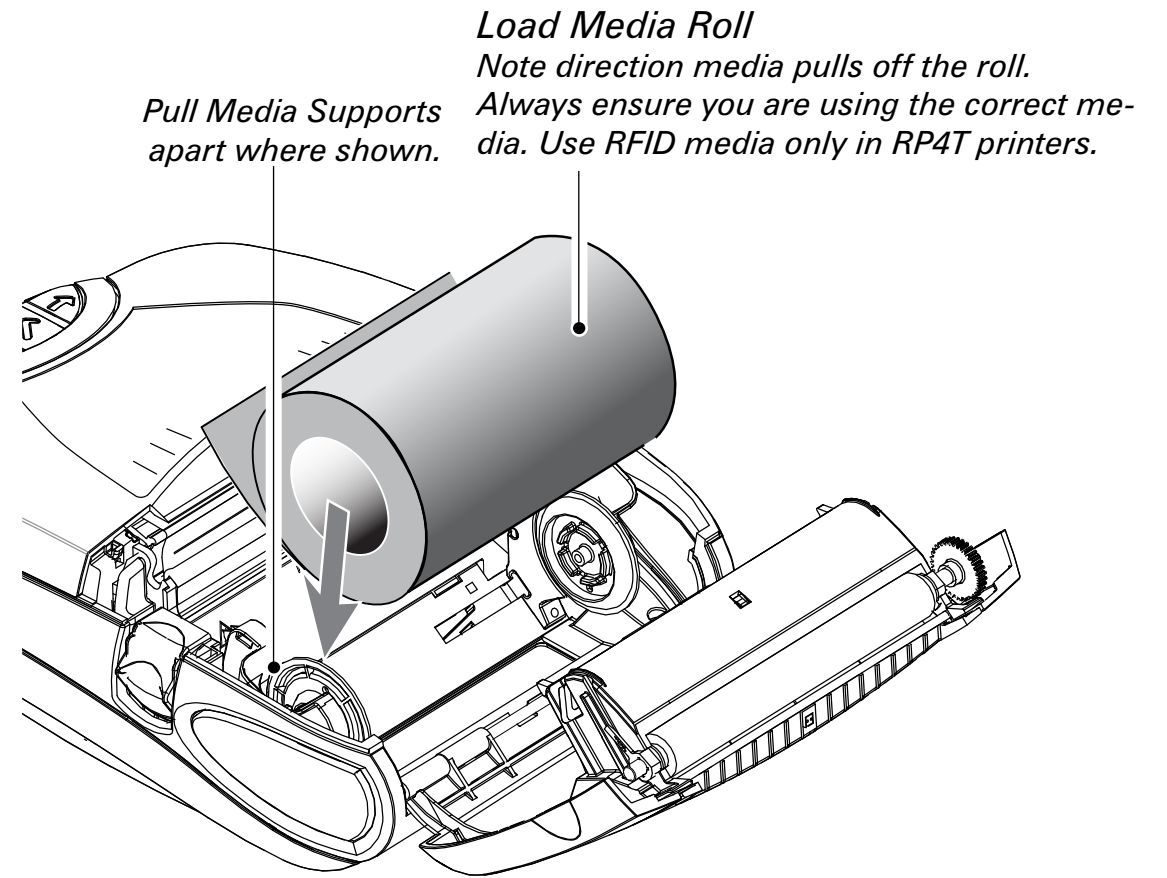

2. Load the Media Roll

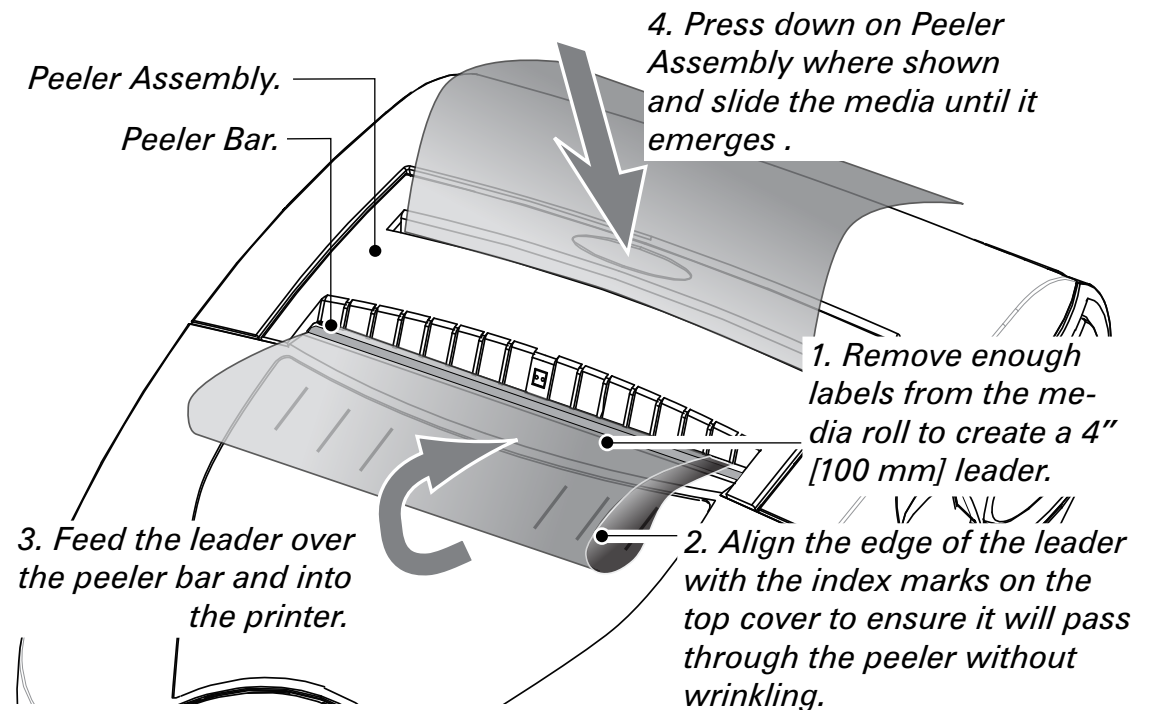

4. Insert Media into Peeler

Optional Step for label stock only

Load the Thermal Transfer Ribbon Cartridge



Use the Thermal Transfer Ribbon Cartridge only when using thermal transfer or RFID media.

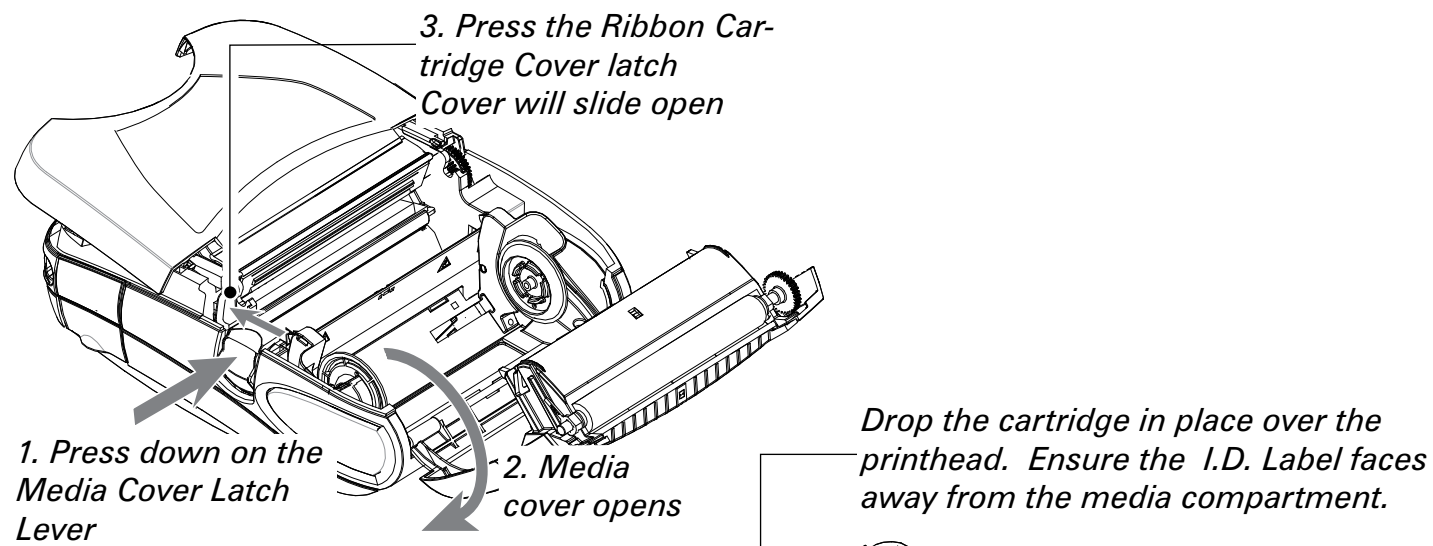

1. Open the Printer Covers

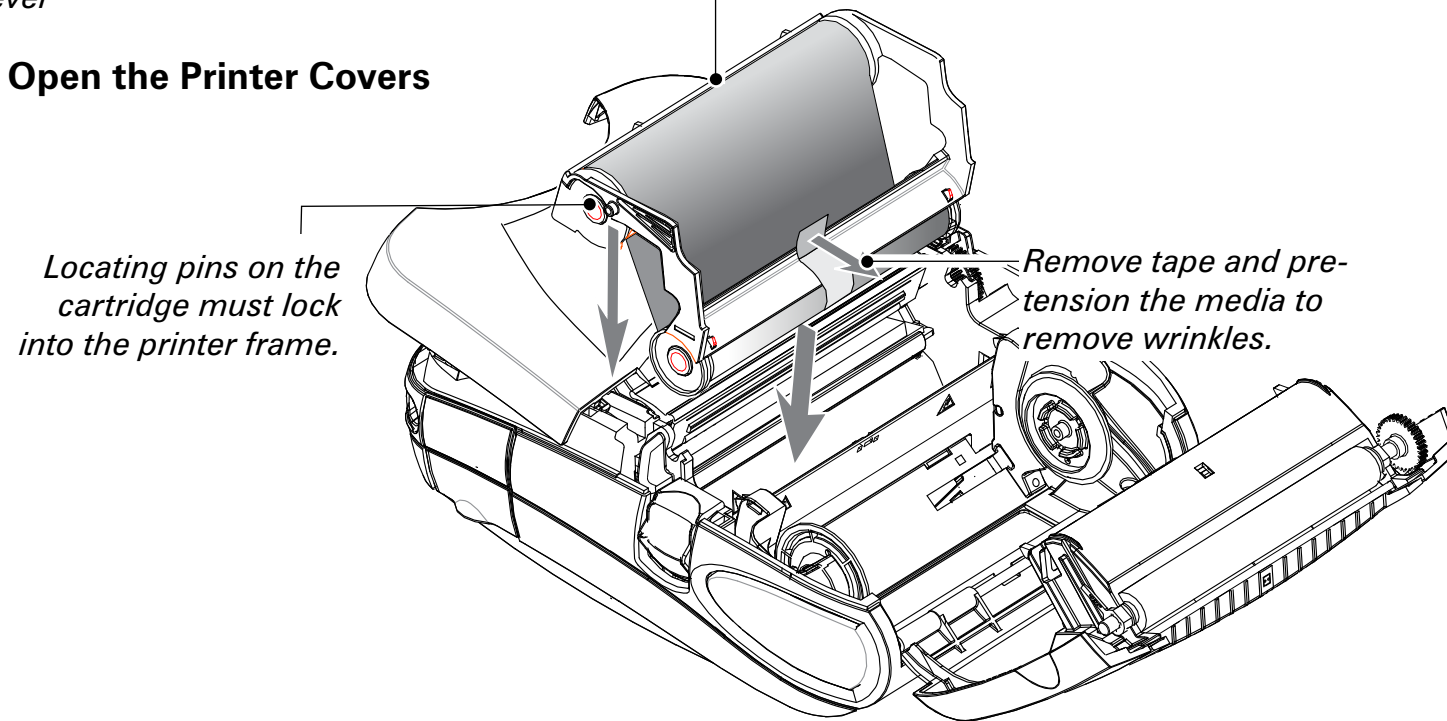

2. Load the Ribbon Cartridge Cartridge

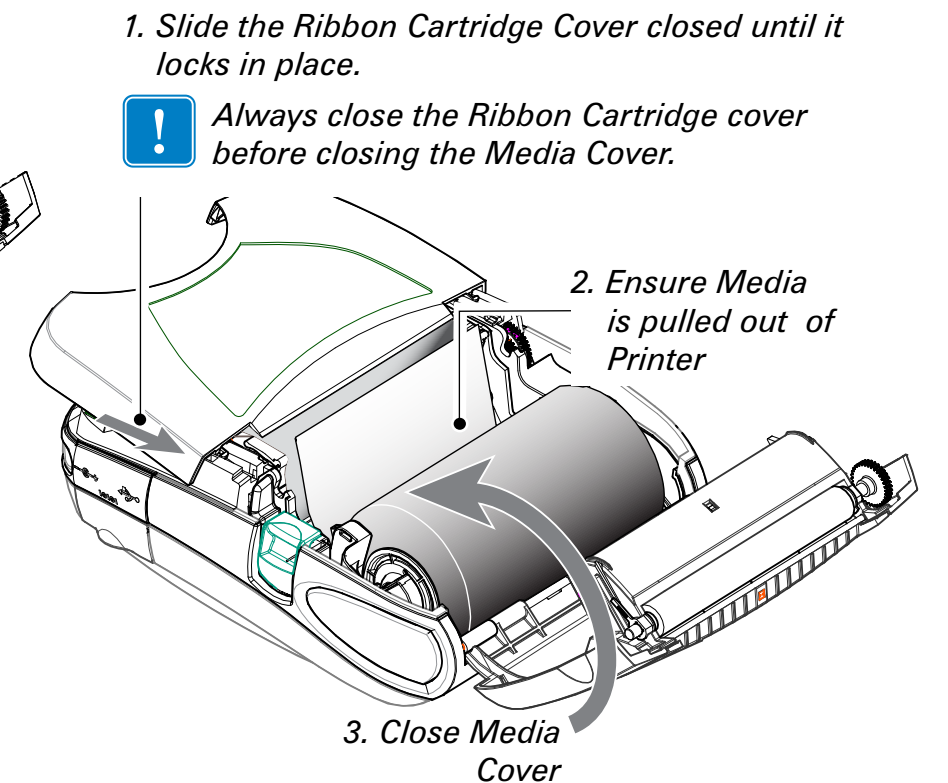

3. Close the Printer Covers

Connect the Printer

Connect The Printer With a Cable

You can connect your printer to a terminal or a PC using either RS232C or USB protocols. Refer to the Label Vista™ application available at www.zebra.com/software for help on setting up communications with your printer.

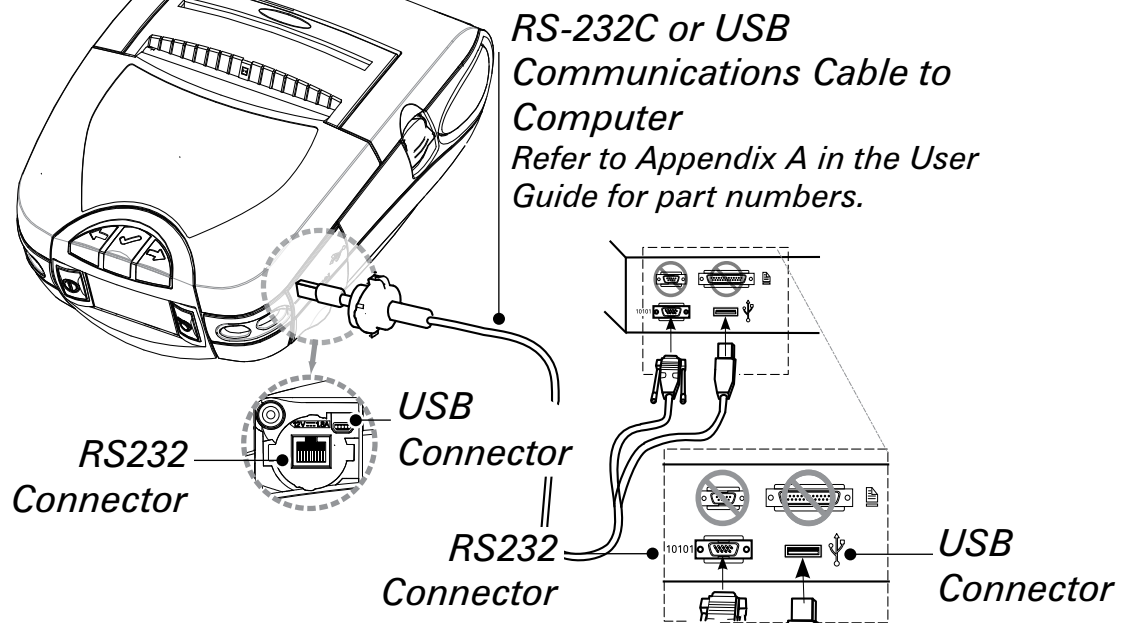
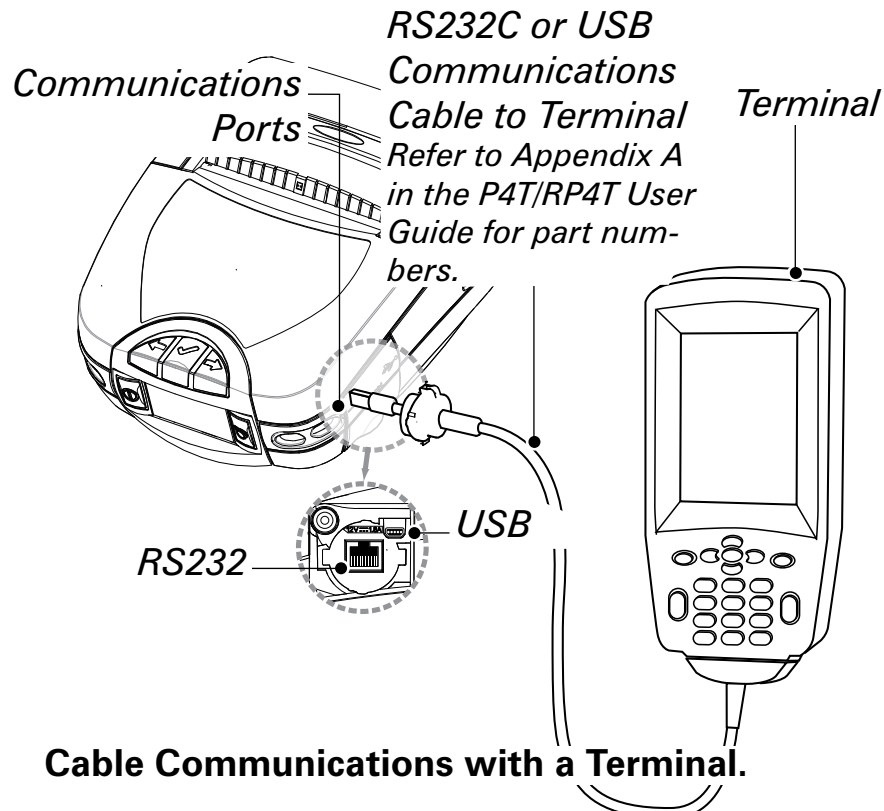

Connect the Printer by Radio

If your P4T Series printer has a radio option, you can connect wirelessly to either a terminal or a wireless network (WLAN.) A P4T printer can use either 802.11x and/or Bluetooth protocols for wireless connections. An RP4T printer can have only one radio option (802-11x or Bluetooth) in addition to the RFID encoder. Refer to the Mobile Printer Wireless Configuration Guide available at www.zebra.com/manuals for help on setting up wireless communications with your printer.

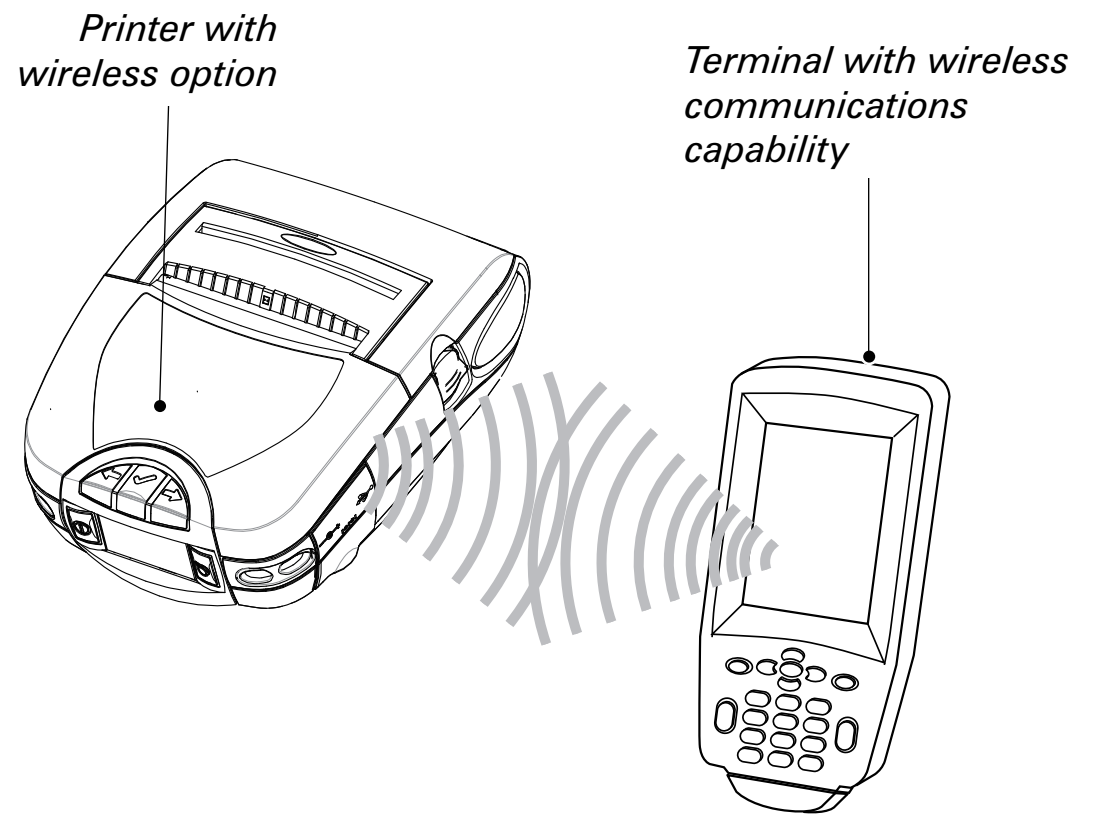

Printer Controls

LCD and Keypad

Refer to the *P4T/RP4T User Guide* for complete information.

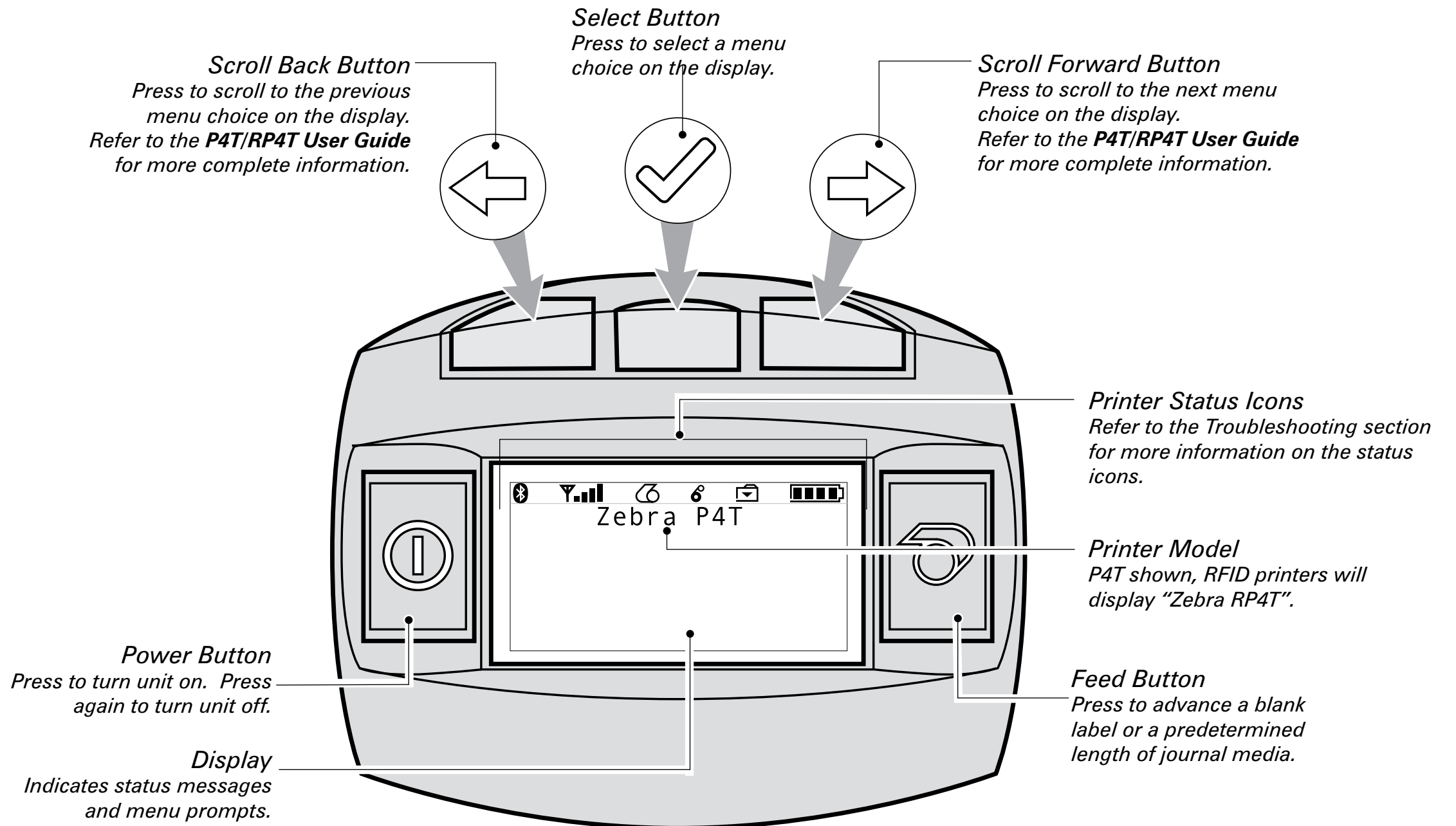

Adjustable Shoulder Strap

An adjustable shoulder strap is supplied with each printer. Its use is detailed below.

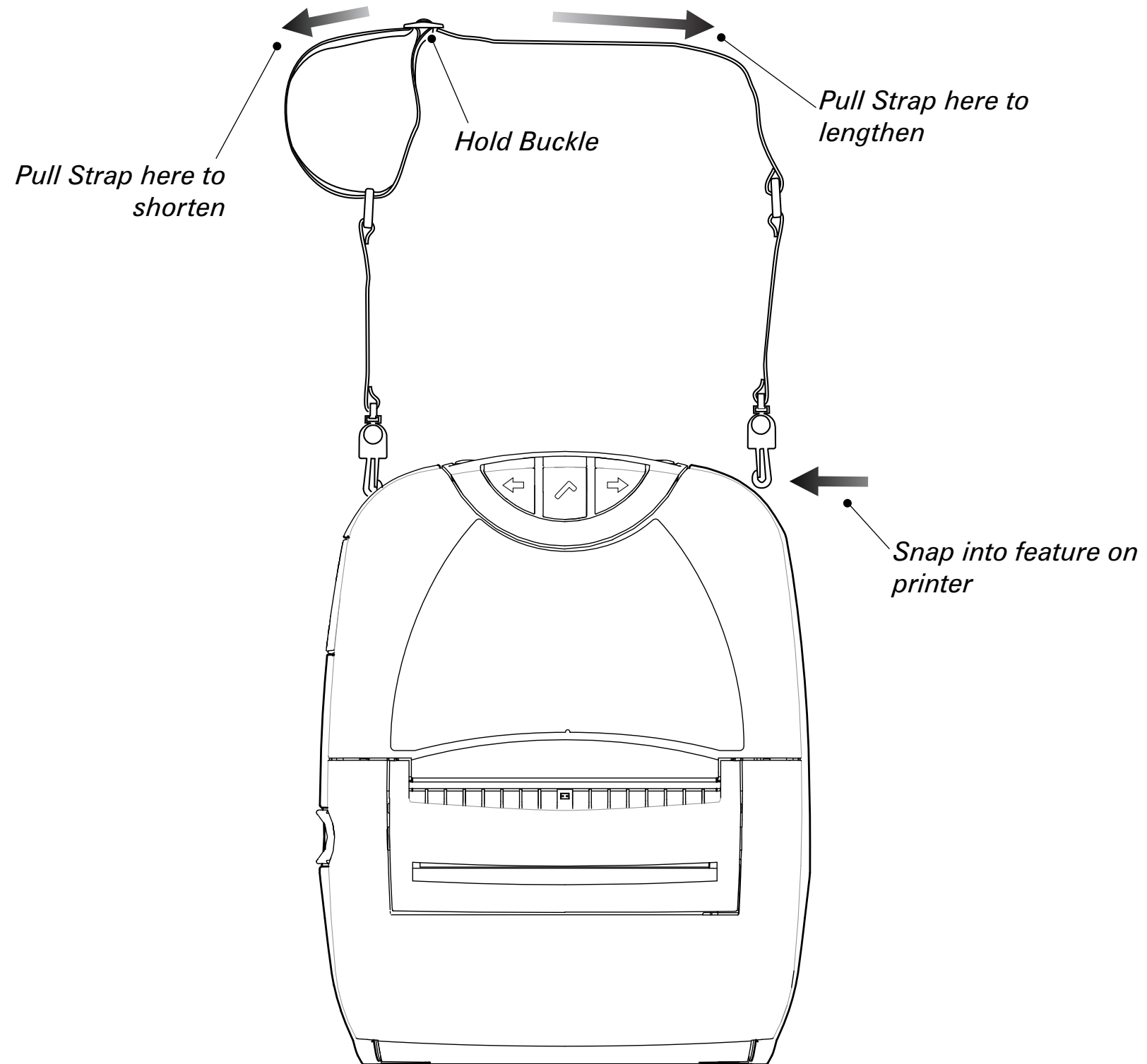

- Snap each end of the shoulder strap into the retaining features on top of the printer.
- Hold the buckle and adjust the strap as shown until you achieve the desired length.

Cleaning the Printer

Caution • To avoid possible personal injury or damage to the printer never insert sharp or pointed objects into the printer mechanism.

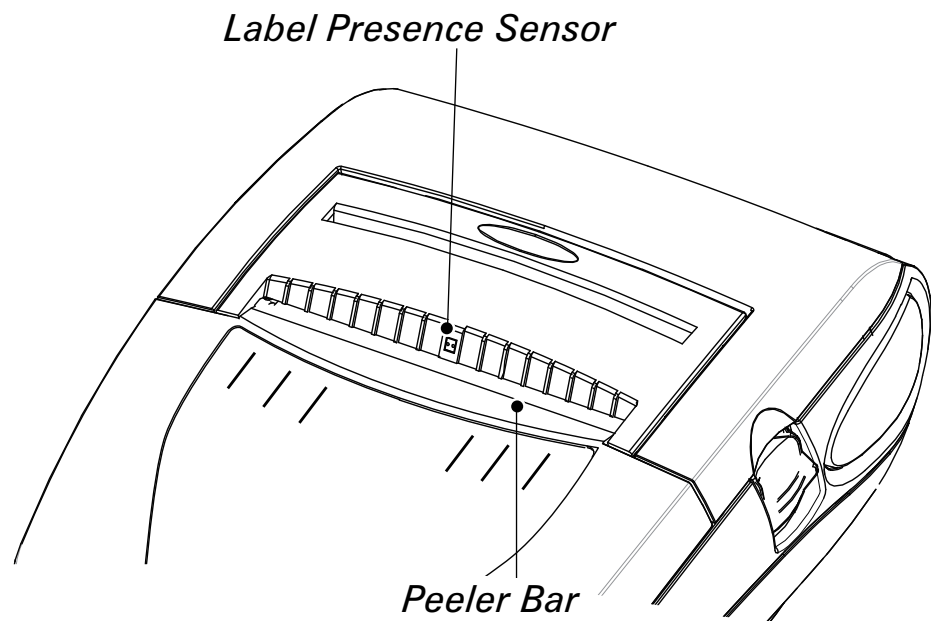
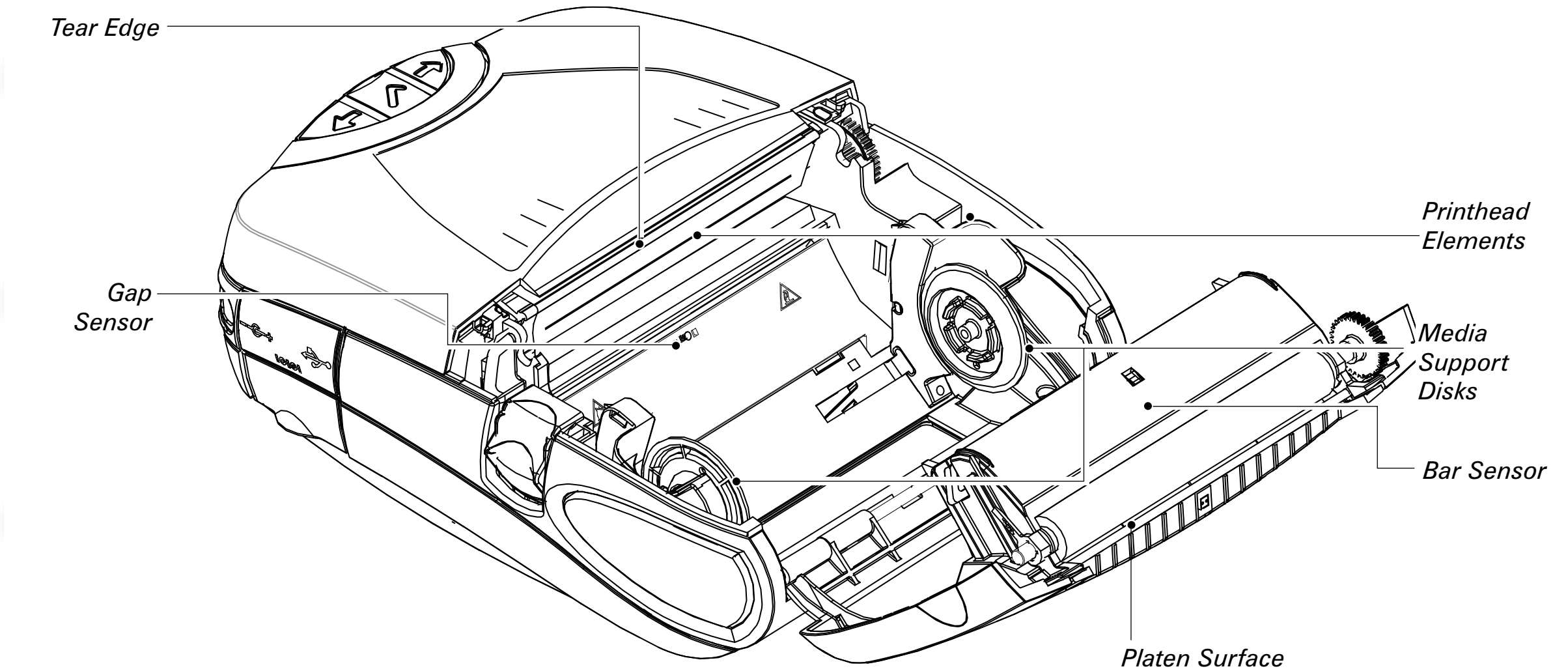







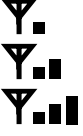

Area	Cleaning Method	Interval
Printhead Elements	Use the supplied cleaning pen to clean the print elements from end to end (the print elements are located in the thin gray line on the printhead).	After every five rolls of media (or more often, if needed)
Platen Surface	Rotate the platen roller and clean it thoroughly with the cleaning pen.	
Peeler Bar Tear Edge	Clean thoroughly with the cleaning pen.	As needed
Exterior	Wipe with water-dampened cloth	
Interior	Brush/air blow. Ensure the Bar Sensor, Gap Sensor and Label Present Sensor windows and the Media Support Disks are free of dust.	

Troubleshooting

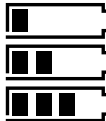
LCD Control Panel

The top of the display shows icons indicating the status of various printer functions. Check the icon's status and refer to the referenced Troubleshooting topic on the following pages.

Icon	Status	Indication	Ref. to Troubleshooting Topic
	On	Bluetooth link established	n/a
	Off	No Bluetooth link	6,8
	On	802.11b/g RF Link established	n/a
	Off	No 802.11b/g RF Link	6,8
		Number of bars indicates 802.11g signal strength	n/a
	Outer element flashing	Low Battery	4, 6,
		Number of bars indicates battery charge level. Display will cycle through the charge level icons if it is undergoing a charge from the AC Adapter.	n/a
	Alternate Flashing	Battery pack too hot or too cold to charge	2
	Flashing	Out of Media	9
	Flashing	Ribbon Cartridge depleted	9
	Flashing	Data processing in process	n/a
Blank Screen	n/a	Battery voltage too low to turn printer on or no application loaded	1,14

Troubleshooting Topics

1. No power:

- Check that battery pack is installed properly.
- Recharge or replace battery pack as necessary.
- If the battery voltage is outside of the printer's operating range and the AC Adapter is plugged into printer, the printer will not turn on. The battery will start to charge, but will give no indication that the battery is charging. When the battery voltage reaches a valid operating range, the printer will still not turn on unless the user manually turns it on, or unplugs and re-plugs the charge cable.

2. AC Adapter is plugged in and the battery icon is flashing or :

- Indication that the battery is out of its safe charging temperature range. Charging will resume when the battery reaches a safe charging temperature.

Troubleshooting Topics (continued)

3. *Media does not feed:*

- Be sure printhead is closed and latched.
- Check media support components for any binding.
- If unit is equipped with label presence sensor, ensure the most recently printed label is removed.
- Ensure label sensor is not blocked.

4. *Poor or faded print or icon flashing:*

- Clean printhead.
- Check battery pack. Recharge or replace as necessary. Always dispose of batteries according to local regulations. Refer to Appendix E in the P4T/RP4T Users Guide for more information.
- Check quality of media.

5. *Partial/missing print:*

- Check Ribbon Cartridge and/or label media alignment.
- Clean printhead.
- Ensure printhead is properly closed and latched.

6. *No print:*

- Replace battery pack.
- Check cable to terminal.
- Wireless units only: Restore wireless connection.
- Units using Thermal Transfer media: Ensure a Ribbon Cartridge has been installed.

7. *Reduced charge life:*

- Check battery pack date code. If battery pack is one to two years old, short life may be due to normal aging.
- If the battery pack has exceeded its maximum limit of charge cycles the printer will indicate that the battery pack needs re-conditioning or replacing.
- Replace battery pack.

8. or icon off:

- Units with Bluetooth or 802.11g option only: indicates no radio link has been established.

9. or flashing:

- Check that both label media and a Ribbon Cartridge are loaded and that the printhead is closed and securely latched.

10. *Skips labels:*

- Ensure correct media is being used.
- Ensure bar/ or gap sensor is not blocked.

11. *Prints “wrinkle pattern” or partial characters:*

- Ensure thermal transfer ribbon has been tensioned prior to installation. Problem will self-correct after printing a few labels.
- Ensure label media tracks properly when emerging from printer. Use the alignment marks on the media cover to ensure wrinkle free operation when loading media into the peeler assembly. Correct media alignment if necessary.

12. *Prints multiple “Void” messages:*

- RP4T printers only: Ensure you have installed RFID media. Printer cannot verify RF encoding on non-RFID media and will print “Void” on a pre-set number of labels before stopping.

Troubleshooting Topics (continued)

13. *Communication Error:*

- Check that media is loaded, head is closed and all error indicators are off.
- Replace cable to terminal.

14. *Screen blank*

- No application loaded. Attempt to re-load application and restart printer.
- No power. See Topic "1" of this section.

Contact Us

For product support, and the latest versions of all customer documentation, contact Zebra Technologies at: www.zebra.com

Refer to Appendix D in the P4T/RP4T User Guide for more detailed contact information

IN THE AMERICAS CONTACT:

Zebra Technologies International, LLC

333 Corporate Woods Parkway
Vernon Hills, Illinois 60061-3109 USA
Phone: +1.847.793.2600 or +1.800.423. 0422
Fax: +1.847.913.8766

IN EUROPE, AFRICA, THE MIDDLE EAST, AND INDIA CONTACT:

Zebra Technologies Europe Limited

Zebra House
The Valley Centre, Gordon Road
High Wycombe
Buckinghamshire HP13 6EQ, UK
Phone: +44.1494.472872
Fax: +44.1494.450103

IN THE ASIA PACIFIC REGION CONTACT:

Zebra Technologies Asia Pacific, LLC

Go to www.zebra.com/contact for complete contact information.
Phone: +65-6858 0722
Fax: +65-6885 0838



Zebra Technologies International, LLC

333 Corporate Woods Parkway
Vernon Hills, Illinois 60061-3109 USA